



Miniveyor Support Feet Kit

(Part No. MVA-072010)

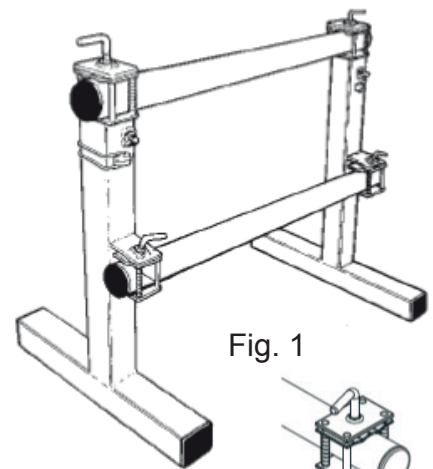
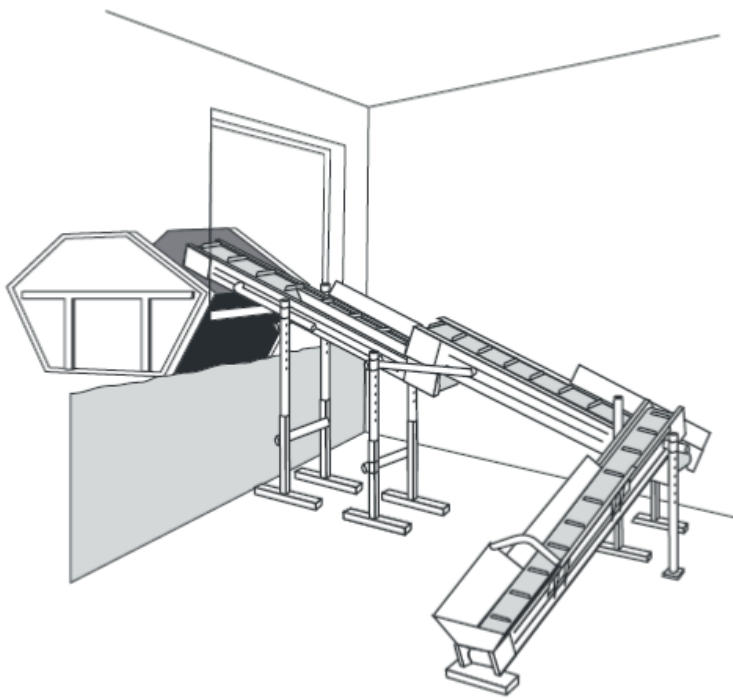

Fig. 1

The Miniveyor Support Feet Kit is an invaluable accessory that allows a user to set up multiple Miniveyor units quickly and simply without the need for tools. The kit consists of three pairs of telescopic legs, mounting tubes, cantilever link and fixed leg support.

The mounting tubes are inserted through the 50mm construction tube location holes built into each end of the Miniveyor structure and then clamped through the top mounting clamp on each leg. A further mounting tube is fixed through the lower side clamp on the leg for support. See figure 1.

When clamping the mounting tubes you must ensure that the tube is level with the end of the top or side clamp or protruding any distance required through the side clamp. You must pay particular attention to ensure that the tube itself is level with the edge of the top or side clamp and not the end caps as this would mean that the tube itself is 5mm short of being flush with the edge. See figures 2 and 3.

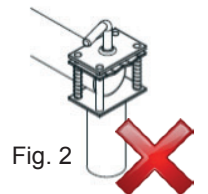
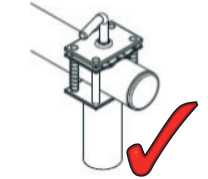

Fig. 2

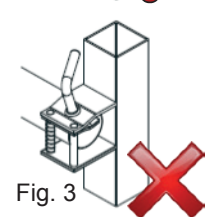
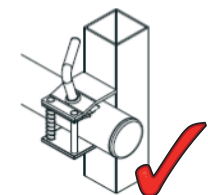

Fig. 3

miniveyor.co.nz

SALES . LEASE . HIRE . CALL 0800 744 382

PO Box 38 485, Howick, Auckland 2145, New Zealand. Email: dave@miniveyor.co.nz

THE OFFICAL AUTHORISED NEW ZEALAND AGENT AND OPERATOR